



# powerstor™

## Featuring F.I.R.E.E. Technology

Product code: PWR2

- » Safely charge Li-ion batteries on site with 32x sockets in a single, easily managed unit.
- » Lockable and secure walk-in 2m deep unit helps reduce tool theft.
- » Proactive and reactive features to tackle risk of Li-ion battery fire.



### Product features



240V charging



2x 5-lever deadlocks



Audio alert



Automatic fire suppression



Lighting



Power supply 240V



Ventilation



Visual alert

### Specifications

Weight	540kg
Colour	Black grey: RAL 7021
Suitable for	Lithium-Ion battery charging
Finished coating	Galvanised and powder coated
Material & thickness	1mm and 2mm steel
Quantity of keys	3 keys
Suitable for vehicle mounting	No
How are castors fitted?	Not applicable
Other sizes available	1 other size
Qty of shelves as standard	5 shelves (515mm depth)

### Dimensions - External dimensions includes protrusions

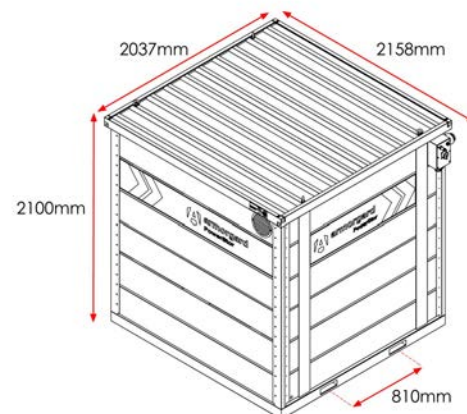

### Optional extras - Contact Armorgard to find out more



BlokkaBar FRBL2



Lockable Shelves FRLS2

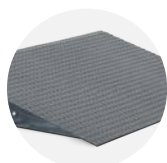

Ramp FRR4

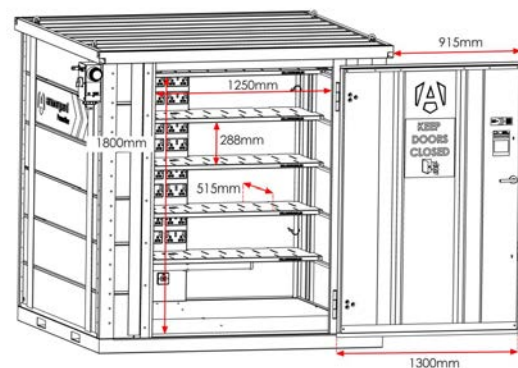

Disclaimer: all dimensions and weights are approximate